

ITEM NO.	QTY.	PART NO.	DESCRIPTION
1	1	50457	CONVEYOR WMT
2	1	50458	SLIDE PLATE WMT
3	1	11460	HOSE COVER
4	1	11462	PLASTIC WEAR PLATE
5	2	11463	RETAINING STRAP
6	3	11436	STRAP, WEAR STRIP MOUNT
7	3	11469	PLASTIC WEAR STRIP
8	128	70189	.38 FLAT WASHER
9	40	70150	.38UNC WHIZ NUT
10	1	50459	ROLLER MOTOR MTG. SLIDE WMT
11	1	11471	TIE BAR
12	1	11474	RETAINING STRAP
13	1	11475	RUBBER STRAP
14	1	11476	RETAINING STRAP
15	1	11466	RUBBER STRAP
16	1	11467	RUBBER STRAP
17	35	70039	.38UNC X 1.25 CAPSCREW
18	2	70021	.25UNC X .75 CAPSCREW
19	3	70149	.25UNC WHIZ NUT
20	1	11465	MOUNTING STRAP
21	1	60268	DOUBLE HOSE CLAMP
22	53	70130	.38UNC NYLOCK NUT
23	37	70332	.38UNC X 1.75 ALLEN HEAD TAPER BOLT
24	4	10632	CENTERING GUIDE
25	8	70296	.38UNC X 1.25 ALLEN HEAD TAPER BOLT
26	3	60032	FLANGE BEARING, 4 BOLT, 1.25
27	2	60029	FLANGE BEARING, 4 BOLT, 1.00
28	8	70116	.38 SAE FLAT WASHER
29	16	70117	.44 SAE FLAT WASHER
30	12	70131	.44UNC NYLOCK NUT
31	8	70265	.44UNC X 2.00 CARRIAGE BOLT
32	12	70041	.38UNC X 1.75 CAPSCREW
33	2	50466	BEARING ADJUSTER WMT
34	10	70017	.50UNC NUT
35	2	70333	.50UNC X 10.00 READI BOLT
36	20	70191	.50 FLAT WASHER
37	1	70026	.25UNC X 2.00 CAPSCREW
38	1	60262	CROWN PULLY 8" X 22"
39	1	60026	WHEEL HUB
40	1	60243	CROWN PULLY 6" X 22"
41	1	60180	HYDRAULIC MOTOR
42	1	50473	BELT VIBRATOR 22"
43	4	70151	.50UNC WHIZ NUT
44	4	70064	.50UNC X 2.75 CAPSCREW
45	5	70164	.50 LOCK WASHER
46	5	70252	.50UNF X 1.25 CAPSCREW
47	1	60265	CONVEYOR BELT
48	2	66039	ELBOW, 45° 8MJ-10MBO
49	1	50482	CYLINDER MTG. WMT
50	8	70059	.50UNC X 1.50 CAPSCREW
51	8	70132	.50UNC NYLOCK NUT
52	1	60453	BELT SPLICE PIN WITH/KEEPER PINS

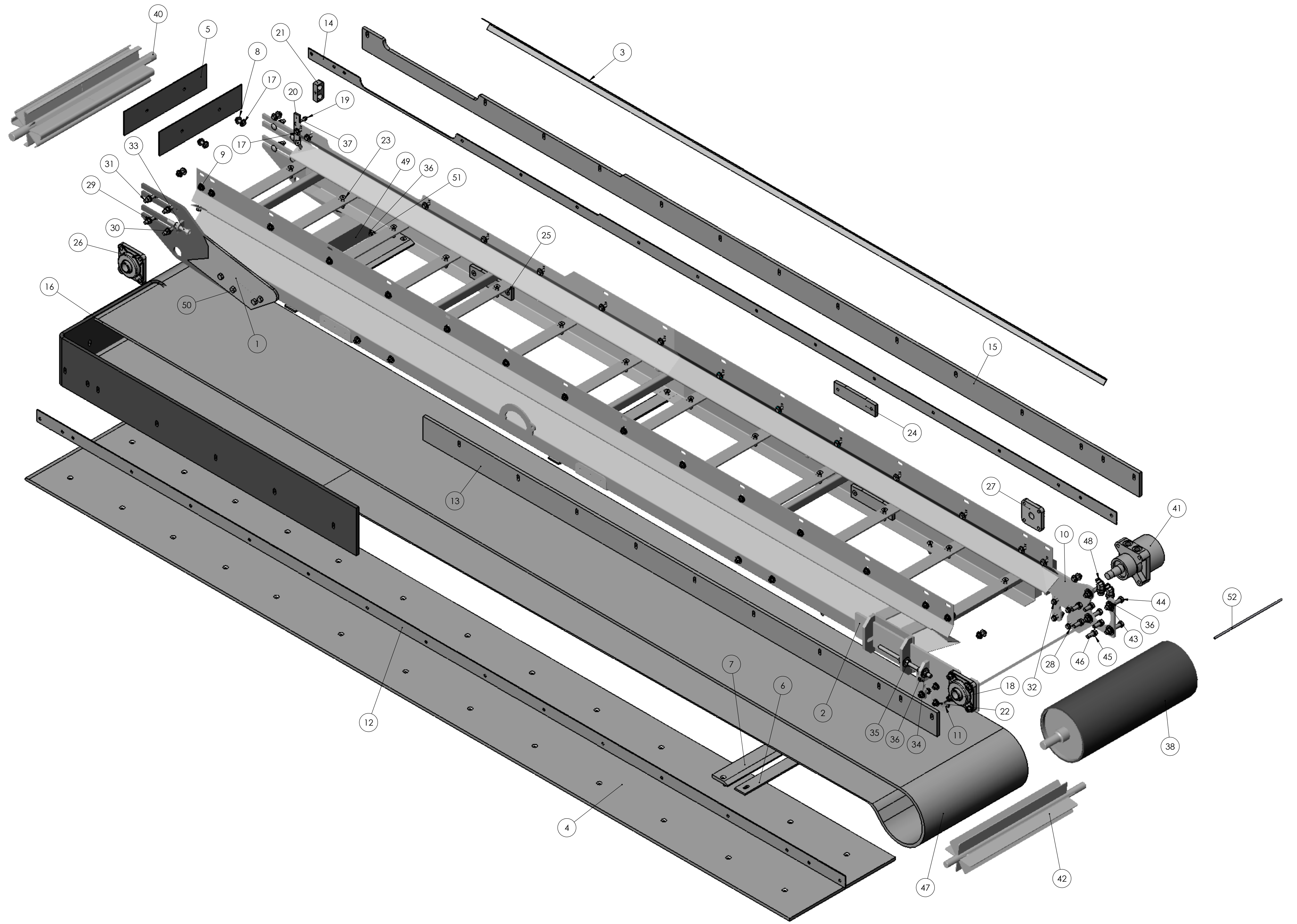

BINDERS: 5

TOLERANCE DECIMAL XX +/- .03 .XXX +/- .06 .XXXX +/- .010		THIS DRAWING AND ALL INFORMATION THEREON IS PROPERTY OF ORBIT SCREENS, INC. AND MUST NOT BE USED IN ANY WAY WITHOUT PRIOR CONSENT OR IN ANY WAY DETRIMENTAL TO THE INTEREST OF ORBIT SCREENS.		704#	XX	90007
ANGULAR +/- 1 DEGREE UNLESS OTHERWISE SPECIFIED		3RD ANGLE PROJECTION		WEIGHT	MATL QTY	FIRST USED
E		DRAWN	DATE	TITLE		
D		SI	07/16/07	BELT CONVEYOR ASSY. 20' X 13'		
C		CHECKED	DATE	MATERIAL XX		
B		A	RELEASED FOR PRODUCTION 07/16/07	SCALE	DO NOT SCALE DWG	PART NO.
A		REV	DESCRIPTION DATE BY	1:7	DEBURR PART	50460

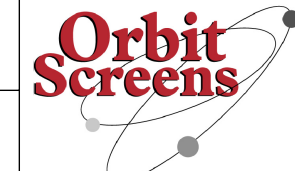

505 3RD STREET
P.O. BOX 345
DELHI, IOWA 52223
PHONE: 563-922-9230
FAX: 563-922-9060

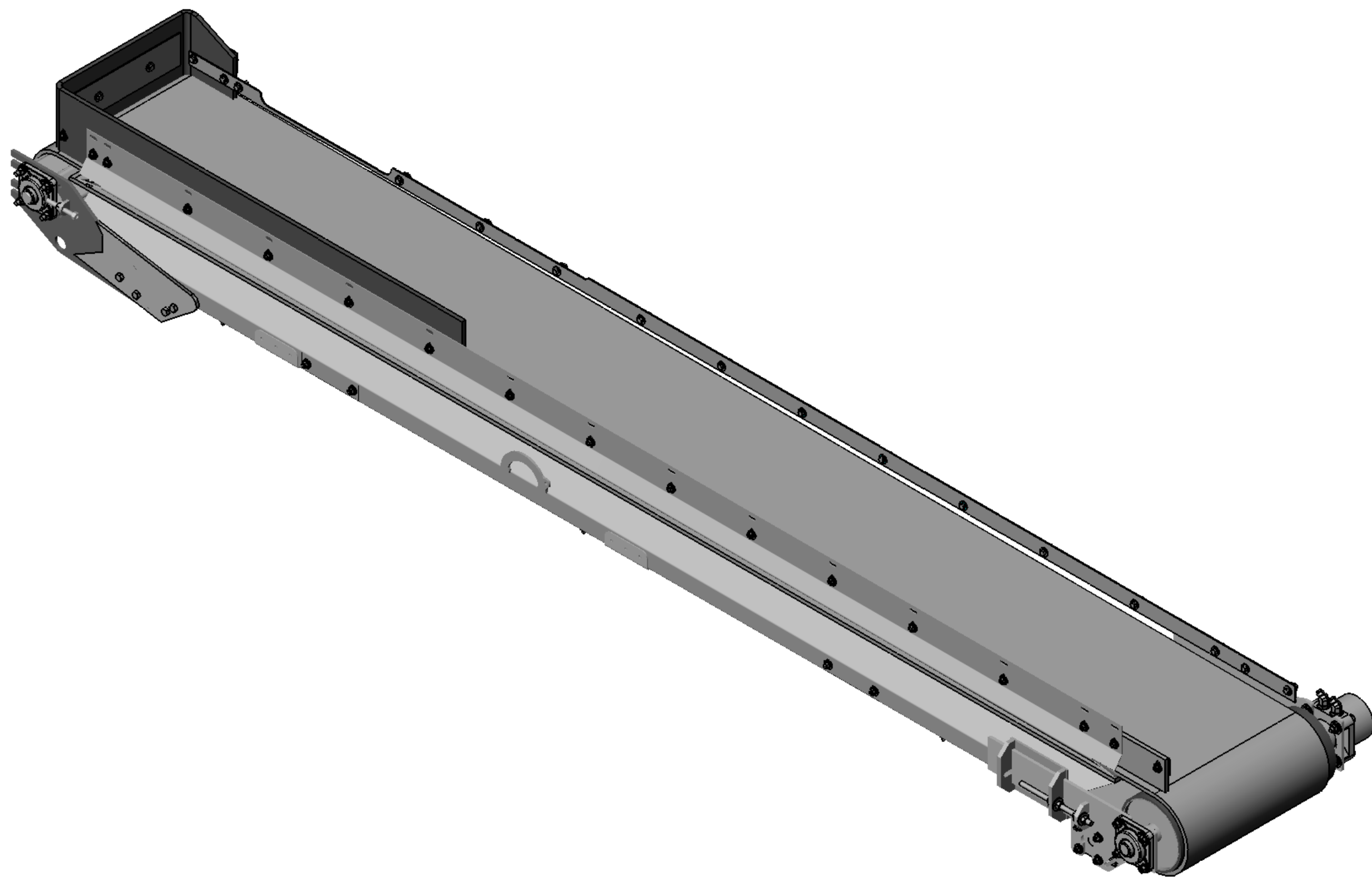

PART NO.
XX

TOLERANCE DECIMAL .XX +/- .06 .XXX +/- .030 .XXXX +/- .010 ANGULAR +/- 1 DEGREE UNLESS OTHERWISE SPECIFIED	THIS DRAWING AND ALL INFORMATION THERON IS PROPRY OF ORBIT SCREENS, INC. AND MUST NOT BE USED IN ANY WAY WITHOUT PRIOR CONSENT OR IN ANY WAY DETRIMENTAL TO THE INTEREST OF ORBIT SCREENS.						XX	XX	XX
	E				DRAWN	DATE	TITLE	XX	XX
	D				XX	XX/XX/XX	MAT'L	XX	XX
	C				CHECKED	DATE	SCALE	DO NOT SCALE DWG	PART NO.
B						X:X	DEBURR PART	XX	
A	XX	XX/XX/XX	XX						
REV	DESCRIPTION	DATE	BY						



505 3RD STREET
 P.O. BOX 345
 DELHI, IOWA 52223
 PHONE: 563-922-9230
 FAX: 563-922-9060

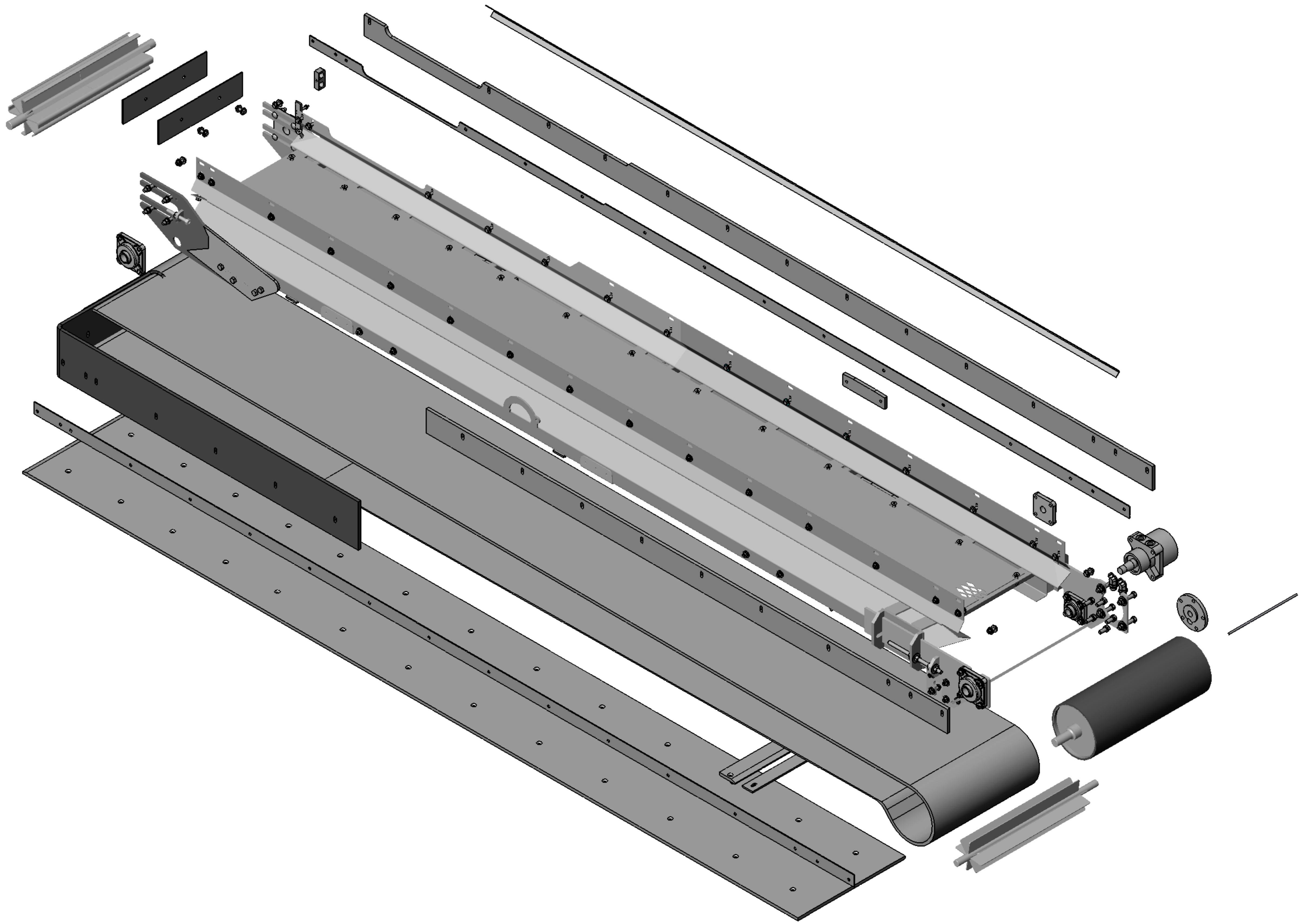

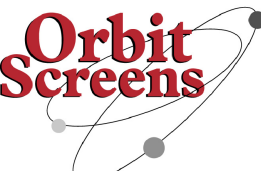
TOLERANCE DECIMAL .XX +/- .03 .XXX +/- .06 .XXXX +/- .010 ANGULAR +/- 1 DEGREE UNLESS OTHERWISE SPECIFIED		THIS DRAWING AND ALL INFORMATION THEREON IS PROPERTY OF ORBIT SCREENS, INC. AND MUST NOT BE USED IN ANY WAY WITHOUT PRIOR CONSENT OR IN ANY WAY DETRIMENTAL TO THE INTEREST OF ORBIT SCREENS.				XX	XX	XX
3RD ANGLE PROJECTION		DRAWN		DATE	TITLE	WEIGHT	MATL QTY	FIRST USED
E		XX	XX/XX/XX	XX				
D		CHECKED	DATE		XX			
C					XX			
B					XX			
A	XX		XX/XX/XX	XX				
REV	DESCRIPTION	DATE	BY					
 505 3RD STREET P.O. BOX 345 DELHI, IOWA 52223 PHONE: 563-922-9230 FAX: 563-922-9060					SCALE	DO NOT SCALE DWG DEBURR PART	PART NO. XX	
					XX			